

Puertas & Portones Automaticos, S.A. de C.V.

¡Nuestra pasión es la Solución!....

» CATALOGO GENERAL DE SISTEMAS CORREDIZOS PARA PORTONES
MARCA MTH.



SLIDING SYSTEM
COMPONENTS

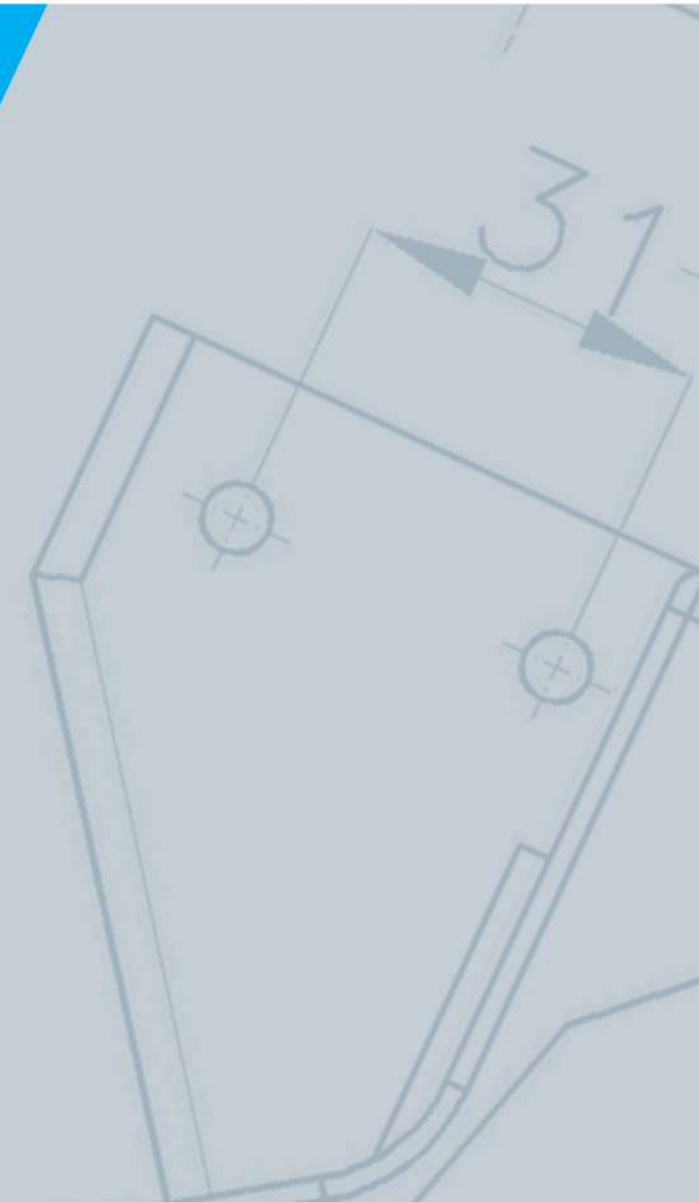

(229) 461-7028



portonesautomaticos@adsver.com.mx
ads.portonesautomaticos@outlook.com



RESIDENCIAL



COMERCIAL



INDUSTRIAL



V05.26



(229) 927-55107, 167-8080, 167-8007, 151-7529

www.adsver.com.mx

CODE CODICE	SIDE LATO / LADO CÔTE / SEITE
----------------	-------------------------------------

24ACT203* Right / Destra / Derecho
Droit / Rechts

24ACT204 Left / Sinistra / Izquierda
Gauche / Links

ALUMINIUM TRACK COVER HEAD FOR "LIGHT" MODEL TRACK
TESTATA PER COPERTINA IN ALLUMINIO
PER BINARIO MODELLO "LIGHT"
CUBIERTA PARA MAMPARA EN ALUMINIO
PARA RIEL MODELO "LIGHT"
TÊTE CACHE RAILLE EN ALUMINIUM POUR MODELE "LIGHT"
KAPPE FÜR ALU-SCHIENENABDECKUNG MODELL "LIGHT"

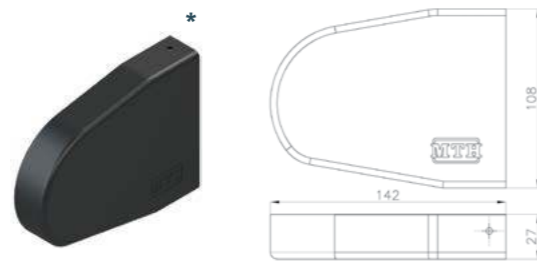

24ACT205

ALUMINIUM CENTRAL JOINT COVER
FOR "LIGHT" MODEL TRACK
COPRIGIUNTO CENTRALE PER COPERTINA IN ALLUMINIO
PER BINARIO MODELLO "LIGHT"
CUBIERTA UNION CENTRAL PARA MAMPARA EN ALUMINIO
PARA RIEL MODELO "LIGHT"
COUVRE JOINT CENTRAL CACHE RAILLE EN ALUMINIUM
POUR MODELE "LIGHT"
VERBINDER FÜR SCHIENENABDECKUNG MODELL "LIGHT"

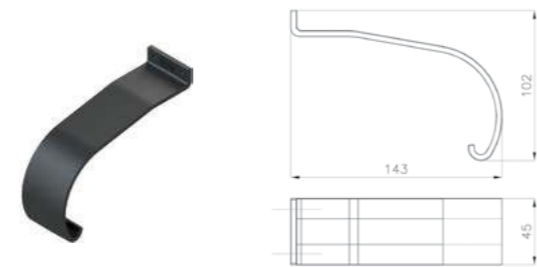

24ACC201

REVERSIBLE BEND FOR "LIGHT" MODEL TRACK
CURVA REVERSIBILE PER BINARIO MODELLO "LIGHT"
RAMPA REVERSIBILE PARA RIEL MODELO "LIGHT"
COURBE REVERSIBLE POUR RAILLE MODELE "LIGHT"
ROLLENABSENKUNG FÜR SCHIENE MODELL "LIGHT"

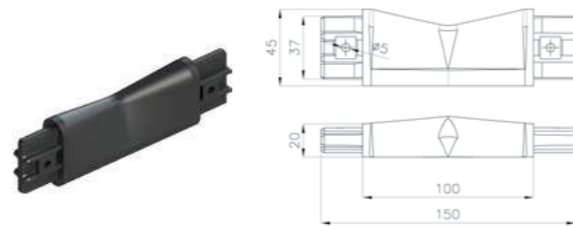

24ACC202

SUPPORT FOR "LIGHT" MODEL TRACK
SUPPORTO PER BINARIO MODELLO "LIGHT"
SOPORTE PARA RIEL MODELO "LIGHT"
SUPPORT POUR RAILLE MODELE "LIGHT"
STÜTZE FÜR SCHIENE MODELL "LIGHT"

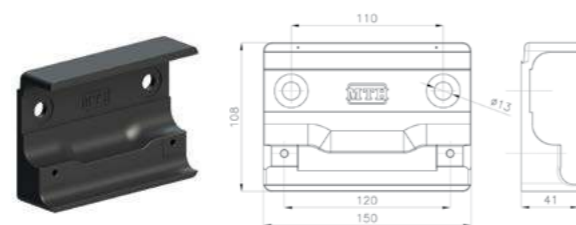

24ACP030

COMPLETE REVERSIBLE OPENING LIMIT STOP
FOR "LIGHT" MODEL TRACK
FERMO CORSA DI APERTURA COMPLETO REVERSIBILE
PER BINARIO MODELLO "LIGHT"
TOPE DE FIN DE CARRERA DE ABERTURA COMPLETA
REVERSIBLE PARA RIEL MODELO "LIGHT"
FIN DE COURSE DE OUVERTURE INTÉGRALE
REVERSIBLE POUR RAILLE MODELE "LIGHT"
ANSCHLUSSSTROPFEN FÜHRUNGSBEGINN KOMPLETT
FÜR SCHIENE MODELL "LIGHT"

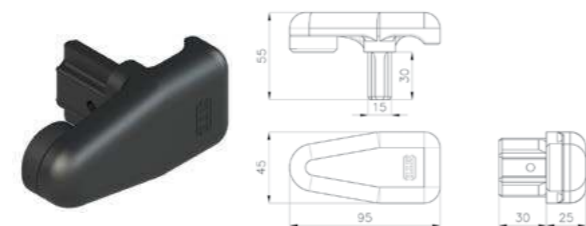

360 LS
360 FLS

24ACP031

COMPLETE REVERSIBLE CLOSING LIMIT STOP
FOR "LIGHT" MODEL TRACK
FERMO CORSA DI CHIUSURA COMPLETO REVERSIBILE
PER BINARIO MODELLO "LIGHT"
TOPE DE FIN DE CARRERA DE CIERRE
COMPLETO REVERSIBLE PARA RIEL MODELO "LIGHT"
FIN DE COURSE DE FERMETURE INTÉGRALE REVERSIBLE
POUR RAILLE MODELE "LIGHT"
ANSCHLUSSSTOPFEN FÜHRUNGSSENDE KOMPLETT
FÜR SCHIENE MODELL "LIGHT"



CODE CODICE	SIDE LATO / LADO CÔTE / SEITE	PIN PERNO / PERNO PIVOT / STIFT
24CPT600*	Right / Destra / Derecho Droit / Rechts	Galvanized Zincato / Galvanizado Zinc / Verzinktem
24CPT601	Left / Sinistra / Izquierda Gauche / Links	
24CPT602	Right / Destra / Derecho Droit / Rechts	Stainless Steel Inox / Edelstahl
24CPT603	Left / Sinistra / Izquierda Gauche / Links	

UNIVERSAL PLASTIC PULLEY WITH PA WHEEL
CARRUCOLA UNIVERSALE IN PLASTICA
CON RUOTA IN PA
POLEA UNIVERSAL EN PLASTICO
CON RUEDA EN PA
POULIE UNIVERSEL EN PLASTIQUE
AVEC ROULETTE EN PA
KUNSTSTOFFROLLE MIT HALTER UNIVERSAL

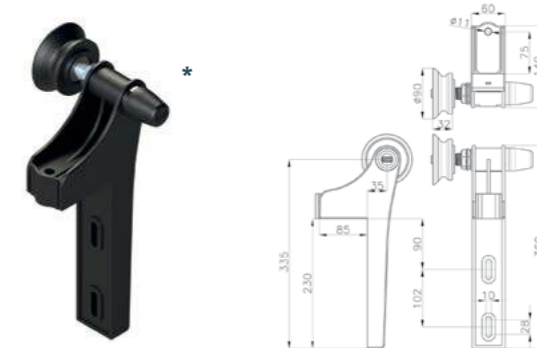

CODE CODICE	SIDE LATO / LADO CÔTE / SEITE	PIN PERNO / PERNO PIVOT / STIFT
24CIT310	Right / Destra / Derecho Droit / Rechts	Galvanized Zincato / Galvanizado Zinc / Verzinktem
24CIT311	Left / Sinistra / Izquierda Gauche / Links	
24CIT301*	Right / Destra / Derecho Droit / Rechts	Stainless Steel Inox / Edelstahl
24CIT302	Left / Sinistra / Izquierda Gauche / Links	

UNIVERSAL STAINLESS STEEL PULLEY WITH PA WHEEL
CARRUCOLA UNIVERSALE INOX CON RUOTA
POLEA UNIVERSAL INOX CON RUEDA EN PA
POULIE UNIVERSEL INOX AVEC ROULETTE EN PA
EDELSTAHLHALTER MIT KUNSTSTOFFROLLE UNIVERSAL

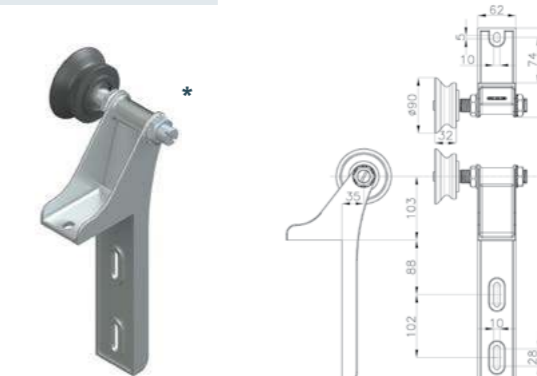

360 LS
360 FLS

480 ATMC
480 PT
480 TN
480 LT
480 LTB
480 LWT
485 LWT
490 LWT

480 ATMC
480 PT
480 TN
480 LT
480 LTB
480 LWT
485 LWT
490 LWT

24BIN002

CENTRAL BLOCK WITH BENDS AND PLUG FOR "MIRROR" MODEL TRACK
BLOCCO CENTRALE COMPLETO DI CURVE PER BINARIO "MIRROR"
BLOQUE CENTRAL COMPLETO DI CURVE PARA RIEL "MIRROR"
BLOC CENTRAL COMPLÉTÉ DE CURVE POUR RAILLE "MIRROR"
ZENTRALE KAPPE KOMPLETT MIT FALLE FÜR MODELL "MIRROR"

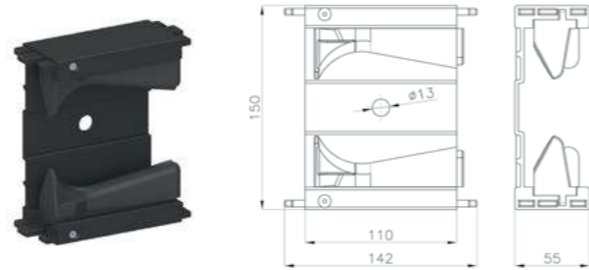

450 GV
480 PGV
480 ATMC
480 ST
480 PT
480 TN
480 LT
480 LTB
480 LWT
485 LWT
490 LWT

24ACT602

OPENING SIDE END PLUG FOR "MIRROR" MODEL TRACK
TAPPO TERMINALE DEL LATO APERTURA PER BINARIO MODELLO "MIRROR"
TAPÓN TERMINAL LADO ABERTURA PARA RIEL MODELO "MIRROR"
BOUCHON TERMINAL DU CÔTE OUVERTURE POUR RAILLE MODELE "MIRROR"
ANSCHLUSSPFROPFEN FÜR ÖFFNUNGSSEITE FÜR MODELL "MIRROR"

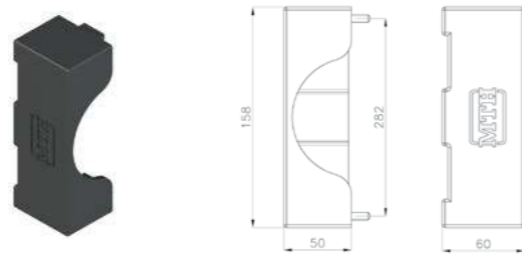

450 GV
480 PGV
480 ATMC
480 ST
480 PT
480 TN
480 LT
480 LTB
480 LWT
485 LWT
490 LWT

CODE CODICE	SIDE LATO / LADO CÔTE / SEITE
24ACT004*	Right / Destra / Derecho Droit / Rechts
24ACT005	Left / Sinistra / Izquierda Gauche / Links

TRACK COVER HEAD FOR CLASSIC MODEL TRACK
TESTATA PER COPERTINA DEL BINARIO MODELLO CLASSICO
CUBIERTA PARA MAMPARA DEL RIEL MODELO CLÁSICO
TÊTE CACHE RAILLE EN ALUMINIUM POUR MODELE CLASSIQUE
KAPPE FÜR SCHIENENABDECKUNG KLASSISCHES MODELL



450 GV
480 PGV
480 ATMC
480 ST
480 PT
480 TN
480 LT
480 LTB
480 LWT
485 LWT
490 LWT

CODE CODICE	OPENING APERTURA / APERTURA OUVERTURE / OFFNUNG
24ACC003* 15087	Right / Destra / Derecho Droit / Rechts
24ACC004 15088	Left / Sinistra / Izquierda Gauche / Links

BEND WITH GROOVE FOR CLASSIC MODEL TRACK
CURVA CON INCAVO PER BINARIO MODELLO CLASSICO
RAMPA CON MUESCA PARA RIEL MODELO CLÁSICO
COURBE AVEC ENTAILLE POUR RAILLE MODELE CLASSIQUE
KURVE MIT VERTIEFUNG FÜR SCHIENE KLASSISCHES MODELL

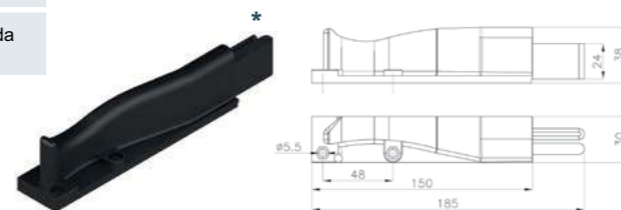

450 GV
480 PGV
480 ATMC
480 ST
480 PT
480 TN
480 LT
480 LTB
480 LWT
485 LWT
490 LWT

CODE CODICE	OPENING APERTURA / APERTURA OUVERTURE / OFFNUNG
24ACC053* 15089	Right / Destra / Derecho Droit / Rechts
24ACC054 15090	Left / Sinistra / Izquierda Gauche / Links

BEND WITHOUT GROOVE FOR CLASSIC MODEL TRACK
CURVA SENZA INCAVO PER BINARIO MODELLO CLASSICO
RAMPA SIN MUESCA PARA RIEL MODELO CLÁSICO
COURBE SANS ENTAILLE POUR RAILLE MODELE CLASSIQUE
KURVE OHNE VERTIEFUNG FÜR SCHIENE KLASSISCHES MODELL

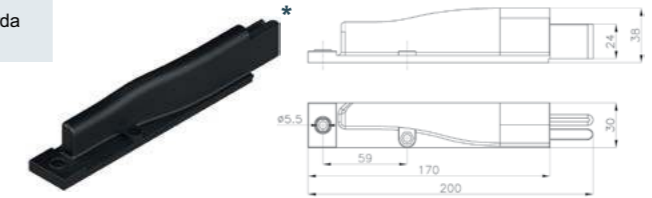

450 GV
480 PGV
480 ATMC
480 ST
480 PT
480 TN
480 LT
480 LTB
480 LWT
485 LWT
490 LWT

24ACP930

COMPLETE REVERSIBLE OPENING LIMIT STOP FOR CLASSIC MODEL TRACK
FERMO CORSA DI APERTURA COMPLETO REVERSIBILE PER BINARIO MODELLO CLASSICO
TOPE DE FIN DE CARRERA DE ABERTURA COMPLETA REVERSIBLE PARA RIEL MODELO CLÁSICO
FIN DE COURSE DE OUVERTURE INTÉGRAL REVERSIBLE POUR RAILLE MODELE CLASSIQUE
UMKEHRBARER LAUFANSCHLAG KOMPLETT FÜR KLASSISCHES MODELL

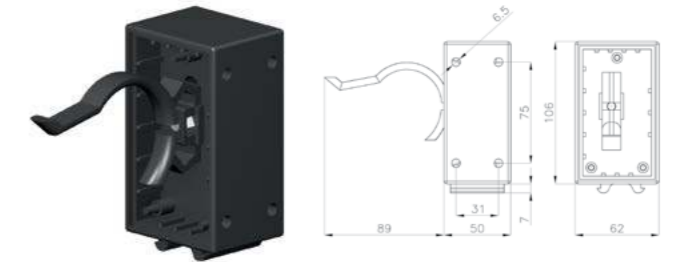

450 GV
480 PGV
480 ATMC
480 ST
480 PT
480 TN
480 LT
480 LTB
480 LWT
485 LWT
490 LWT

CODE CODICE	OPENING APERTURA / APERTURA OUVERTURE / OFFNUNG
24ACP001* 15035	Right / Destra / Derecho Droit / Rechts
24ACP002 15036	Left / Sinistra / Izquierda Gauche / Links

OPENING LIMIT STOP FOR CLASSIC MODEL TRACK
FERMO CORSA DI APERTURA PER BINARIO MODELLO CLASSICO
TOPE DE FIN DE CARRERA DE ABERTURA PARA RIEL MODELO CLÁSICO
FIN DE COURSE DE OUVERTURE POUR RAILLE MODELE CLASSIQUE
LAUFROLLENANSCHLAG FÜR SCHIENE KLASSISCHES MODELL

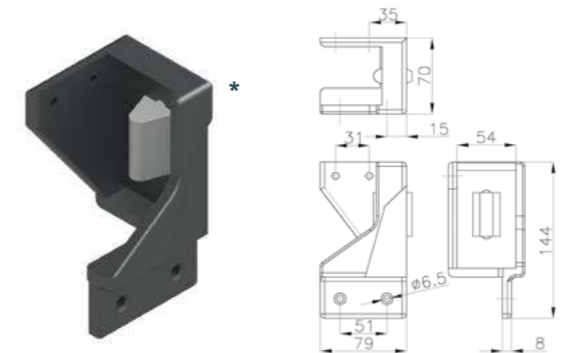

ST. STEEL DOOR:
450 GV
480 PGV
480 ATMC
480 ST
480 PT
480 TN
480 LT
480 LTB
480 LWT
485 LWT
490 LWT

24RIN200 16036

COMPLETE STAINLESS STEEL REGISTER FOR FLOOR GUIDE
REGISTRO INOX PER GUIDA A PAVIMENTO COMPLETO
REGISTRO INOX PARA GUÍA A PISO COMPLETO
REGISTRE INOX POUR GUIDE A SOL INTÉGRAL
BODENFÜHRUNGSROLLE MIT EDELSTAHLPLATTE KOMPLETT

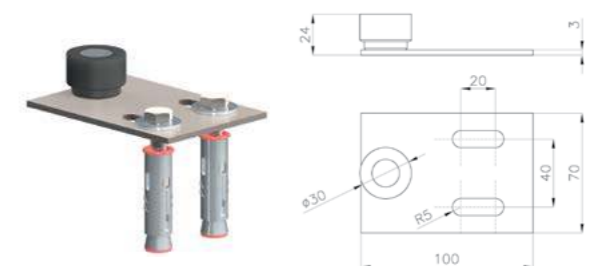

240 S
360 LS
480 ST

24RCT201

BLACK COVER FOR FLOOR GUIDE ENDS
COPERTURA NERA PER ESTREMITÀ GUIDA A PAVIMENTO
CUBIERTA NEGRA PARA EXTREMIDAD GUÍA A PISO
BOUCHON NOIRE POUR EXTRÉMITÉ GUIDE AU SOL
SCHWARZE ABDECKUNG FÜR ENDE BODENFÜHRUNG

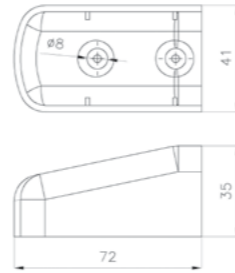

240 S
360 LS
480 ST

24RPV225

REVERSIBLE PLASTIC REAR REGISTER 2.0,
WITH PIN AND ADJUSTABLE ROLLER
REGISTRO POSTERIORE 2.0 IN PLASTICA,
REVERSIBILE CON PERNO E RULLINO REGOLABILE
REGISTRO POSTERIOR 2.0 EN PLÁSTICO,
REVERSIBLE CON PERNO Y RODILLO AJUSTABLE
REGISTRE POSTÉRIEUR 2.0 EN PLASTIQUE,
REVERSIBLE AVEC PIVOT ET ROULEAU RÉGLABLE
ROLLE FÜR WANDFÜHRUNG 2.0 AUS KUNSTSTOFF,
UMKEHRBAR MIT BOLZEN UND REGULIERBARER RÖLLE

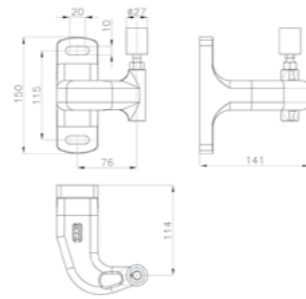

360 FLS
450 GV
480 PGV
480 ATMC
480 PT
480 TN
480 LT
480 LTB
480 LWT
485 LWT
490 LWT

24RIN007

REVERSIBLE STAINLESS STEEL REAR REGISTER 2.0,
WITH PIN AND ADJUSTABLE ROLLER
REGISTRO POSTERIORE 2.0 INOX,
REVERSIBILE CON PERNO E RULLINO REGOLABILE
REGISTRO POSTERIOR 2.0 INOX,
REVERSIBLE CON PERNO Y RODILLO AJUSTABLE
REGISTRE POSTÉRIEUR 2.0 INOX,
REVERSIBLE AVEC PIVOT ET ROULEAU RÉGLABLE
ROLLE FÜR WANDFÜHRUNG 2.0 AUS EDELSTAHL,
UMKEHRBAR MIT BOLZEN UND REGULIERBARER RÖLLE

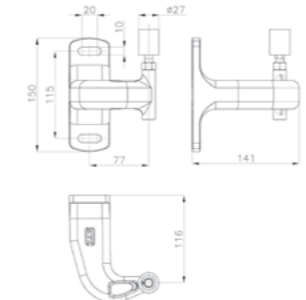

450 GV
480 PGV
480 ATMC
480 PT
480 TN
480 LT
480 LTB
480 LWT
485 LWT
490 LWT

24RCR003

ROLLER WITH THREADED PIN FOR REAR REGISTER
RULLINO COMPLETO DI PERNO FILETTATO
PER REGISTRO POSTERIORE
RODILLO COMPLETO DE PERNO DE ROSCA
PARA REGISTRO POSTERIOR
ROULEAU COMPLÉTÉ DE PIVOT AVEC FILET
POUR REGISTRE POSTÉRIEUR
ROLLE MIT BOLZEN UND GEWINDE

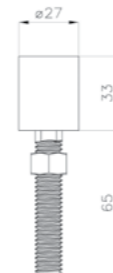

COMPATIBILITY:
24RPV225
24RIN007

CODE CODICE

24RPV001 * 15073

OPENING APERTURA / APERTURA OUVERTURE / ÖFFNUNG

Right / Destra / Derecho
Droit / Rechts

24RPV002 15074

Left / Sinistra / Izquierda
Gauche / Links

REAR REGISTER WITH PIN AND ROLLER
REGISTRO POSTERIORE CON PERNO E RULLINO
REGISTRO POSTERIOR CON PERNO Y RODILLO
REGISTRE POSTÉRIEUR AVEC PIVOT ET ROULEAU
ROLLE FÜR WANDFÜHRUNG MIT BOLZEN UND RÖLLE

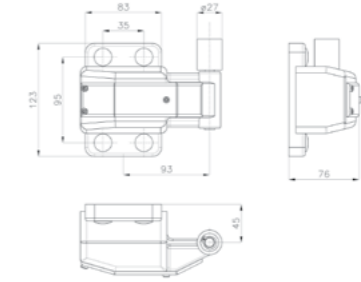

SLIDING DOORS
BEFORE YEAR 2003:
450 GV
480 ATMC
480 TN
480 LWT

CODE CODICE

24RCS910 *

OPENING APERTURA / APERTURA OUVERTURE / ÖFFNUNG

Right / Destra / Derecho
Droit / Rechts

24RCS911

Left / Sinistra / Izquierda
Gauche / Links

REAR GUIDE FIXING BRACKET
STAFFA DI FISSAGGIO PER GUIDA POSTERIORE
ESTRIBO DE FIJACION PER GUÍA POSTERIOR
ETRIER DE FIXAGE POUR GUIDE POSTÉRIEUR
HALTER FÜR DIE WANDFÜHRUNGSSCHIENE
ZUM RAHMEN

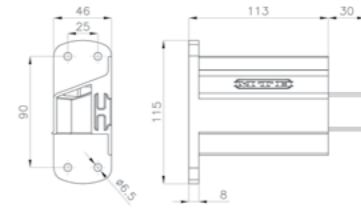

360 FLS
450 GV
480 PGV
480 ATMC
480 PT
480 TN
480 LT
480 LTB
480 LWT
485 LWT
490 LWT

24RCS001 15071

REVERSIBLE REAR GUIDE FIXING BRACKET
STAFFA DI FISSAGGIO REVERSIBILE
PER GUIDA POSTERIORE
ESTRIBO DE FIJACION REVERSIBLE
PER GUÍA POSTERIOR
ETRIER DE FIXAGE REVERSIBLE
POUR GUIDE POSTÉRIEUR
HALTER FÜR DIE WANDFÜHRUNGSSCHIENE
ZUM RAHMEN REGULIERBAR

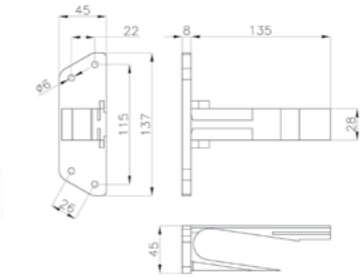

360 FLS
450 GV
480 PGV
480 ATMC
480 PT
480 TN
480 LT
480 LTB
480 LWT
485 LWT
490 LWT

24RCT100 15072

REVERSIBLE REAR GUIDE PLUG
TAPPO REVERSIBILE PER GUIDA POSTERIORE
TAPÓN REVERSIBLE PARA GUÍA POSTERIOR
BOUCHON REVERSIBLE POUR GUIDE POSTÉRIEUR
ENDKAPPE FÜR WANDFÜHRUNGSSCHIENE

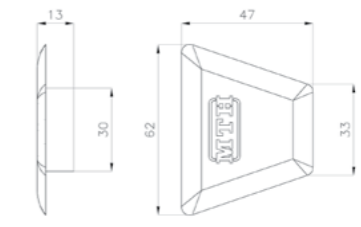

360 FLS
450 GV
480 PGV
480 ATMC
480 PT
480 TN
480 LT
480 LTB
480 LWT
485 LWT
490 LWT

VERTICAL TN
VERTICAL LWT

24GHI845

ENGINE SHEAVE WITH BEARING FOR VERTICAL SLIDING DOOR
PULEGIA MOTORE PER PORTA SCORREVOLE VERTICALE CON CUSCINETTI
POLEA MOTOR PARA PUERTA CORREDERA VERTICAL CON RODAMIENTOS
POULIE MOTEUR POUR PORTE COULISSANTE VERTICAL AVEC COUSSINET
FÜHRUNGSROLLE FÜR VERTIKALE SCHIEBETÜR MIT KUGELLAGER

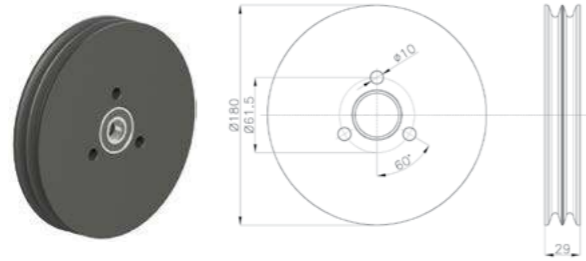

24GHI846

CONDUCTING SHEAVE WITH BEARING FOR VERTICAL SLIDING DOOR
PULEGIA CONDOTTA PER PORTA SCORREVOLE VERTICALE CON CUSCINETTI
POLEA CONDUCTA PARA PUERTA CORREDERA VERTICAL CON RODAMIENTOS
POULIE CONDUITE POUR PORTE COULISSANTE VERTICAL AVEC COUSSINET
FÜHRUNGSROLLE FÜR VERTIKALE SCHIEBETÜR MIT KUGELLAGER

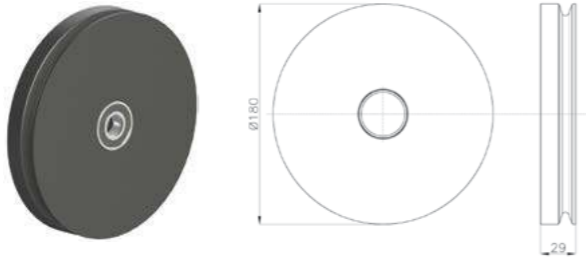

VERTICAL TN
VERTICAL LWT

24GHI810

COMPLETE OPENING LIMIT STOP FOR VERTICAL SLIDING DOOR
FERMO CORSA DI APERTURA COMPLETO PER PORTA SCORREVOLE VERTICALE
TOPE DE FIN DE CARRERA DE ABERTURA COMPLETA PARA PUERTA CORREDERA VERTICAL
FIN DE COURSE DE OUVERTURE INTÉGRAL POUR PORTE COULISSANTE VERTICAL
ÖFFNUNG UMKEHRBARER ENDSCHALTER KOMPLET FÜR VERTIKALE SCHIEBETÜR

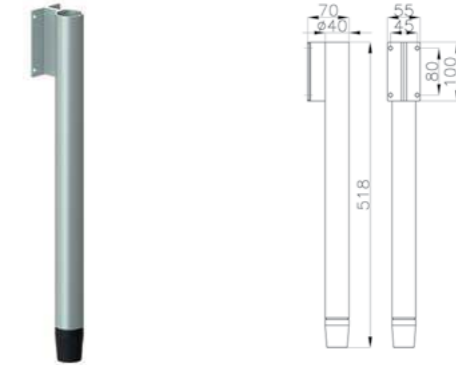

VERTICAL TN
VERTICAL LWT

24GHI872

PLUG FOR VERTICAL SLIDING GUIDE
TAPPO PER GUIDA DI SCORRIMENTO VERTICALE
TAPÓN PER GUÍA DE SCORRIMENTO VERTICAL
BOUCHON POUR GUIDE DE COULISSAGE VERTICAL
PFROPFEN FÜR FÜHRUNG MIT VERTIKALEM SCHLUPF

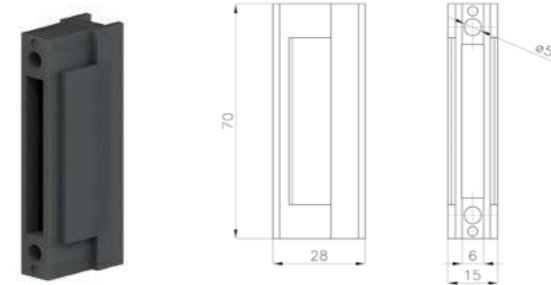

VERTICAL TN
VERTICAL LWT

24GHI841

ANTI-FALL DEVICE FOR VERTICAL SLIDING DOOR
PARACADUTE PER PORTA SCORREVOLE VERTICALE
PARACAÍDAS PARA PUERTA CORREDERA VERTICAL
PARACHUTE POUR PORTE COULISSANTE VERTICAL
ANTI-FALL-GERÄT FÜR VERTIKALE SCHIEBETÜR

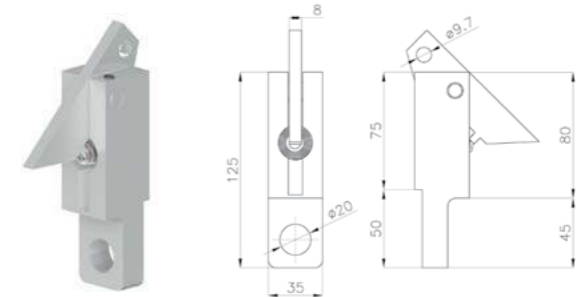

VERTICAL TN
VERTICAL LWT

24GHI840

FULL REGISTER FOR SLIDING VERTICAL DOOR
REGISTRO COMPLETO PER PORTA SCORREVOLE VERTICALE
REGLAJE COMPLETA PARA PUERTA CORREDERA VERTICAL
REGLAGE INTÉGRALE POUR PORTE COULISSANTE VERTICAL
ROLLE KOMPLETT FÜR VERTIKALE SCHIEBETÜR



VERTICAL TN
VERTICAL LWT

CODE CODICE	OPENING APERTURA / APERTURA OUVERTURE / ÖFFNUNG
24GHI870*	Right / Destra / Derecho Droit / Rechts
24GHI871	Left / Sinistra / Izquierda Gauche / Links

BEND FOR VERTICAL SLIDING GUIDE
CURVA PER GUIDA DI SCORRIMENTO VERTICALE
RAMPA PARA GUÍA CORREDERA VERTICAL
COURBE POUR GUIDE DE COULISSAGE VERTICAL
KURVE FÜR FÜHRUNG MIT VERTIKALEM SCHLUPF

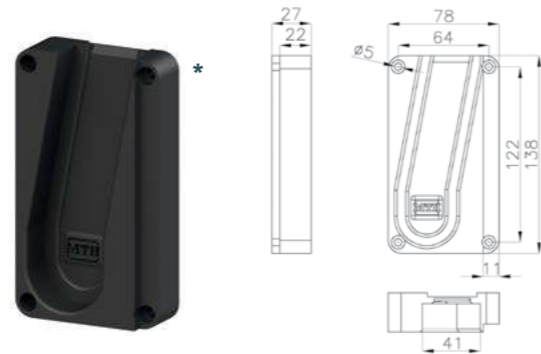

VERTICAL TN
VERTICAL LWT

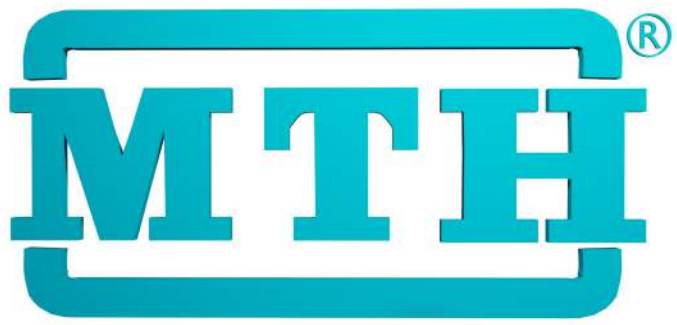

Puertas & Portones Automaticos, S.A. de C.V.

¡Nuestra pasión es la Solución!....

» CATALOGO GENERAL DE SISTEMAS CORREDIZOS PARA PORTONES MARCA MTH.

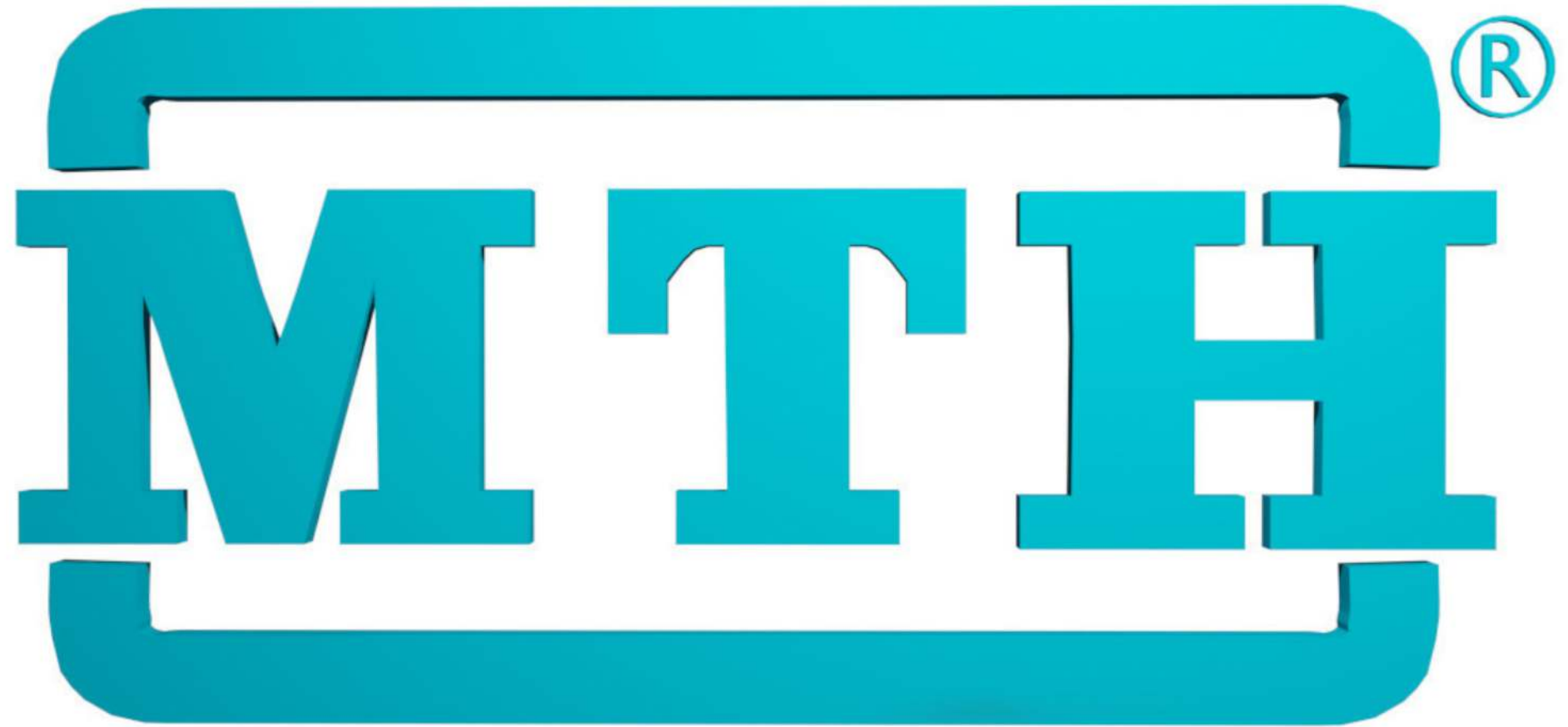

(229) 461-7028

portonesautomaticos@adsver.com.mx
ads.portonesautomaticos@outlook.com



V05.26



(229) 927-55107, 167-8080, 167-8007, 151-7529

www.adsver.com.mx